

Trident Fused Oil Ring Main Unit up to 15.5kV
with automation and remote control options

ENGINEERING BRILLIANT SOLUTIONS

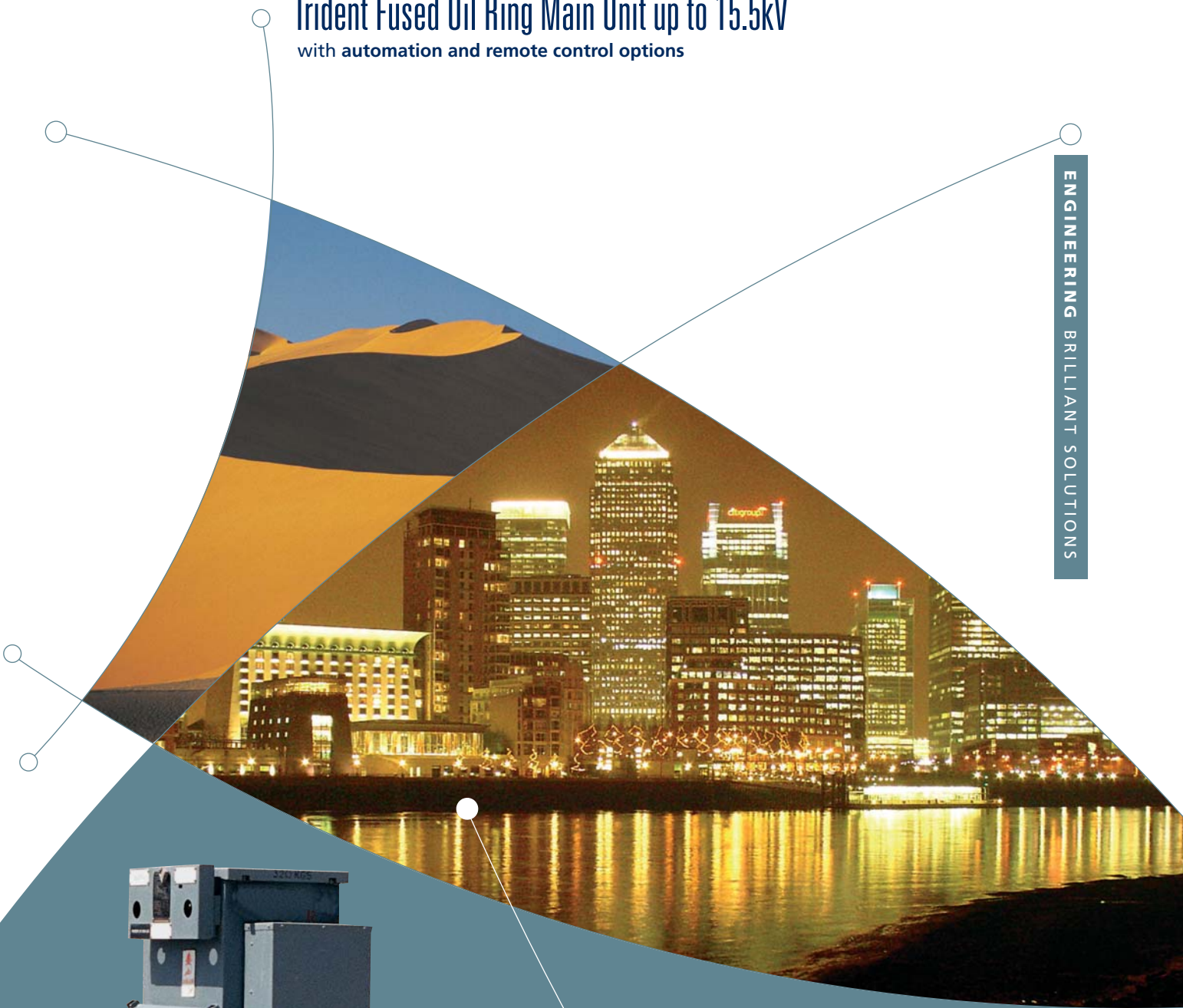

Lucy Switchgear has over 100 years of experience within the power distribution industry. Its Trident range of oil insulated ring main units (RMUs) has been developed over a number of years and is a leading performer in the global market. For use in both rural and industrial settings, it can be positioned in the most extreme conditions: ambient temperatures from -10°C to 55°C , humidity of up to 100%, corrosive regions, oil fields and other hostile environments.

Corrosion Protection

The main body of the unit is fabricated from 4mm steel which is shot blasted, zinc sprayed and then coated with an epoxy powder paint finish for durable outdoor and indoor use.

Maintenance

The Trident range of ring main units requires very low levels of maintenance. Under normal conditions a routine inspection is required at an interval of once every seven years.

Key Features

- Ratings up to 15.5kV
- Long service life
- Low maintenance
- Outdoor
- Isolation in oil
- Interlocked for safe operation
- Padlocking facilities
- Fully extensible
- Robust sheet steel housing



Trident Extensible



Trident Freestanding



Trident with retrofit motor operation



Trident Transformer Mounted



Operation

Mechanism

The operating mechanisms are of the independent manual spring type for both main and earth switches ensuring that speed of operation is independent of the operator.

Ring Switches

Ring switches are fault make, load break three position type 'ON', 'OFF' and 'EARTH ON'.

Fuse Switch

The fused TEE OFF is of the fault make, fault break, three position type 'ON', 'OFF' and 'TRANSFORMER EARTH ON'. The fuse switch has a double isolation feature for additional operational safety.

Safety

The unit has been designed to ensure maximum operator safety. Live parts are contained within an earth sheet steel enclosure. Cable termination boxes are located away from the operator – to the side and the rear, to ensure operator safety at all times. A single line diagram and mechanical indicators exist on the front of each unit to aid user safety and interlocks on all switch positions prevent incorrect operation. In addition padlocking facilities are provided for all positions and can be equipped with neon voltage indicators (live cable indication), interlocked cable test facility on tee-off and Castell interlocking.

Automation

The Trident range of oil ring main units can be fully equipped with automation features to address customers' requirements for remote monitoring and control.

A variety of automation options are available:

- Retrofittable motorised actuator, available as a single LH or RH or double ring switch configuration. Status indicators for the ring switches are also available. The non-intrusive nature of the retrofit assembly negates the need to shut down the unit whilst the installation takes place.
- The tee-off fuse switch can be fitted with a shut trip for remote tripping and auxiliary contacts for remote indication.
- A purposely designed Remote Terminal Unit (RTU) mounting bracket can accommodate our Gemini-RTU on either the right or the left hand side of the Trident RMU.
- Earth fault passage indicators complete the picture by providing crucial information on the location of earth faults in a MV network split ring.

Our Gemini range of automation products and systems ensure an integrated solution, so that the Trident RMU can be monitored and controlled by most utility NMS/SCADA systems.

In essence, our automation solution is a factory built automation package that can be ready for immediate installation with minimal on-site works.

Accessories

Lucy Switchgear has developed a number of accessories that can be added to a Trident RMU providing flexible solutions for our customers.

- Remote tripping
- Ring switch actuators
- RTU mounting bracket
- Earth fault indicators
- Test plug devices
- Busbar connection
- Cabling
- End cap kit

Trident Oil Range Electrical Performance

Product	FRMU	EFS	EOS	DEOS
	RMU	Fuse Switch	Oil Switch	Double Oil Switch
Rated Voltage	15.5kV	15.5kV	15.5kV	15.5kV
Ring Switch				
Rated Current	630A		630A	630A
Making Capacity (Main/Earth)	50kA Pk		50kA Pk	50kA Pk
Breaking Capacity (Main)	630A		630A	630A
Short Time Withstand (Main/Earth)	20kA/3s		20kA/3s	20kA/3s
Basic Impulse Level	95/110kV		95/110kV	95/110kV
Fuse Switch				
Rated Current	200A	200A		
Making Current (Main/Earth)	50kA Pk/7.8kA Pk	50kA Pk/7.8kA Pk		
Breaking Capacity (Main/Earth)95/110kV	20kA	20kA		
Short Time Withstand (Earth)	3.15kA/3s	3.15kA/3s		
Basic Impulse Level	95/110kV	95/110kV		
General				
Rated Frequency	50/60Hz	50/60Hz	50/60Hz	50/60Hz
Minimum Operating Temperature	-10°C to +55°C			
IP Rating	IP54	IP54	IP54	IP54
Weight (without Oil)	320kg	217kg	140kg	320kg
Standards	IEC 60420, 60265-1, 60694, 60294			
Dimensions				
Height (Min)	1262mm	1116mm	1400mm	1185mm
Width	908mm	865mm	642mm	920mm
Depth	757mm	1050mm	600mm	750mm

Trident OIL RMU Range

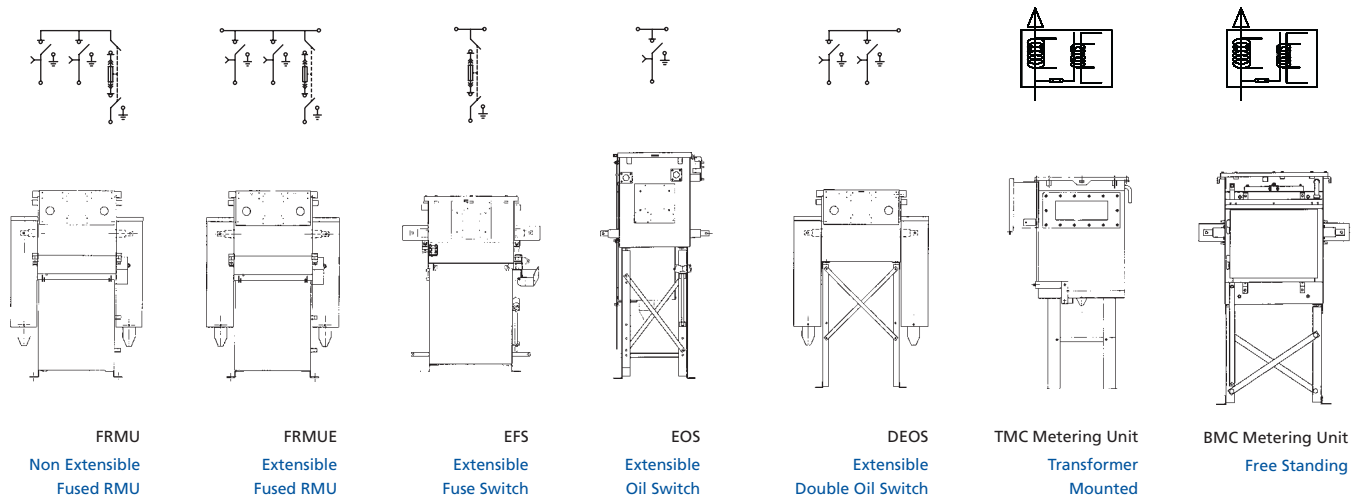

PO Box 17335 • Jebel Ali • Dubai • United Arab Emirates
 telephone: +9714 883 2110
 fax: +9714 883 2113
 email: sales@lucyme.ae

Howland Road • Thame • Oxfordshire OX9 3UJ • United Kingdom
 telephone: +44 (0)1844 267267
 fax: +44 (0)1844 267223
 email: sales@lucyswitchgear.com